



## Modular Cooking Range Line thermaline 85 - Water mixing tap with knobs, 1 Side with Backsplash

ITEM # \_\_\_\_\_

MODEL # \_\_\_\_\_

NAME # \_\_\_\_\_

SIS # \_\_\_\_\_

AIA # \_\_\_\_\_



**588711**  
(MBEBBBBOO) Water mixing tap with knobs, one-side  
operated with backsplash

### Short Form Specification

Item No. \_\_\_\_\_

Water mixing tap with knobs for hot and cold water. Unit constructed according to DIN 18860\_2 with 20 mm drop nose top and 70 mm recessed plinth. Internal frame for heavy duty sturdiness in stainless steel. 2 mm top in 1.4301 (AISI 304). Flat surface construction, easily cleanable. THERMODUL connection system enables seamless worktop when units are connected and avoids soil penetrating.

IPX5 water resistant certification.

Configuration: Freestanding, one side operation with backsplash.

### Main Features

- All major components may be easily accessed from the front.
- THERMODUL connection system creates a seamless work top when units are connected to each other thus avoiding soil penetrating vital components and facilitating the removal of units in case of replacement or service.
- Water mixing unit for hot and cold water.
- Large stainless steel tap.

### Construction

- 2 mm top in 1.4301 (AISI 304).
- Unit constructed according to DIN 18860\_2 with 20 mm drop nose top and 70 mm recessed plinth.
- IPX5 water resistance certification.
- Flat surface construction with minimal hidden areas to easily clean all surfaces
- Internal frame for heavy duty sturdiness in stainless steel.

APPROVAL: \_\_\_\_\_



**Optional Accessories**

- Connecting rail kit for appliances with backsplash, 850mm PNC 912498
- Back panel, 200x700mm, for units with backsplash PNC 913007
- Endrail kit, flush-fitting, with backsplash, left PNC 913115
- Endrail kit, flush-fitting, with backsplash, right PNC 913116
- Endrail kit (12.5mm) for thermaline 85 units with backsplash, left PNC 913206
- Endrail kit (12.5mm) for thermaline 85 units with backsplash, right PNC 913207
- Insert profile, d=850mm PNC 913231
- Stainless steel side panel (12,5mm), 850x400mm, left side, wall mounted PNC 913632
- Stainless steel side panel (12,5mm), 850x400mm, right side, wall mounted PNC 913633
- Stainless steel side panel (12,5mm), 850x400mm, flush-fitting, left side, wall mounted PNC 913634
- Stainless steel side panel (12,5mm), 850x400mm, flush-fitting, right side, wall mounted PNC 913635
- Wall mounting kit top - TL85/90 - Factory Fitted PNC 913646

Front

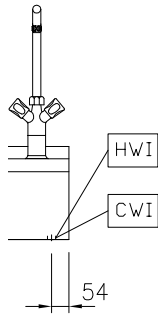

Side

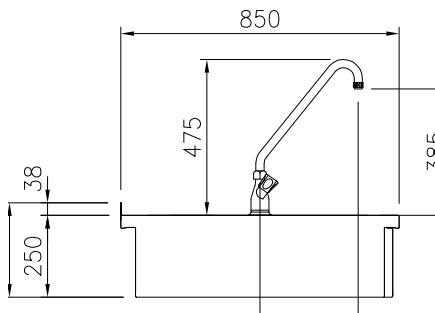

CWI = Cold Water inlet 1 (cleaning)  
 HWI = Hot water inlet

Top

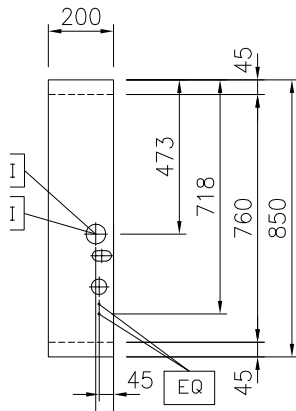
**Water:**

Inlet water line size:	3/4"
Incoming Cold/hot Water line size:	3/4"

**Key Information:**

External dimensions, Width:	200 mm
External dimensions, Depth:	850 mm
External dimensions, Height:	250 mm
Net weight:	15.5 kg